

ESCO
LIFESCIENCES



Airstream®

Class I Biological Safety Cabinets

The Leading Energy Efficient, Quiet, and Ergonomic Biosafety Cabinet

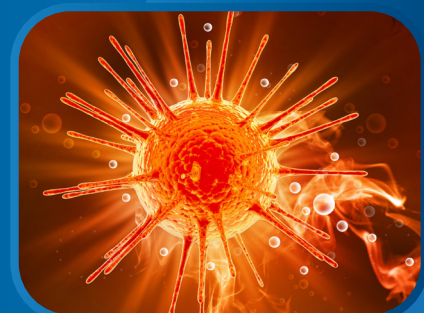



Welcome to Esco Lifesciences

Esco Lifesciences' vision is to provide enabling technologies for scientific discoveries to make human lives healthier and safer.

Esco Lifesciences is committed to delivering innovative solutions for the clinical, life sciences, research, industrial, laboratory, pharmaceutical, and IVF communities. With the most extensive product line in the industry, Esco has passed a number of international standards and certifications. Esco Lifesciences represents innovation and forward-thinking designs, that are of the highest standard quality since 1978.

Availability and Accessibility. Esco Lifesciences has headquarters in Singapore, Indonesia, and Philippines, with manufacturing facilities located in Asia and Europe. Research and Development (R&D) is conducted worldwide spanning the US, Europe and Asia. Sales, services, and marketing subsidiaries are located in 42 major markets including US, UK, Japan, China and India. Esco regional distribution centers are located in Singapore, Malaysia, Thailand, Vietnam, Myanmar, Indonesia, Philippines, Bangladesh, Hong Kong, Taiwan, South Korea, China, Japan, India, UAE, Central and South Africa, Denmark, Germany, Italy, Lithuania, Russia, United Kingdom, and USA. Because of our worldwide presence, you can be sure that Esco is within your reach.

High Quality, Reliable, and Dependable. Esco Lifesciences products are of high quality, reliable, and dependable. Cross-functional teams from Esco Production, R&D, Quality Assurance, and Senior Management, are regularly assembled to review and implement areas for improvement.

2

Esco Lifesciences Cares for Your Safety. Esco Lifesciences focuses on providing safety not just for your samples, but also for you and the environment.

Esco Lifesciences Cares for Your Comfort. Building ergonomic designs and reducing noise levels of the units ensure comfort for our users.

Esco Lifesciences Cares for the Environment. Esco Lifesciences incorporates the latest proven technologically advanced components available. One in every four of Esco's employees is involved in Research and Development and are evaluating new components or designs for better efficiency. Whenever a new technology is available, Esco Lifesciences redesigns technology into our new products that will use lesser energy.

Customer Service and Support. Our service does not stop once purchase has been done. Esco Lifesciences gives on-time customer service such as service training, preventive maintenance, and re-certification, to respond to your equipment needs. Esco Lifesciences also offers free end-user seminars and provides educational materials and informative videos.

As Esco Lifesciences takes the opportunity to respond to the world's needs, we aim not only to contribute to the advancement of scientific discoveries but also in making the world a safer, healthier, and better place to live in.



Products and Applications

Life Sciences Laboratory Equipment

Sample Preparation

- Class I Biological Safety Cabinets
- Class II Biological Safety Cabinets
- Class II Type A2 Biological Safety Cabinets
- Class II Type B1 Biological Safety Cabinets
- Class II Type B2 Biological Safety Cabinets
- Class III Biological Safety Cabinets
- Horizontal Laminar Flow Cabinets
- Vertical Laminar Flow Cabinets
- Laboratory Animal Research Workstations
- Laboratory Centrifuges

Sample Cultivation

- CO₂ Incubators, Direct Heat Air-Jacketed
- CO₂ Incubators with Cooling System
- CO₂ Incubators with High Heat Sterilization
- Laboratory Shakers

Amplification and Detection

- Conventional Thermal Cyclers
- Microplate Shakers
- PCR Cabinets

Sample Storage & Sample Protection Solutions

- Laboratory Refrigerators and Freezers
- Ultra-low Temperature Freezers
- Remote Monitoring, Datalogging, and Programming Software
- Wireless Monitoring System

Chemical Research

- Ducted Fume Hoods
- Ductless Fume Hoods
- Filtered Storage Cabinets
- Powder Weighing Balance Enclosure
- Exhaust Blowers
- Fume Hood Airflow Monitor

General Equipment

Laboratory Thermostatic Products

- Forced Convection Laboratory Oven
- Forced Convection Laboratory Incubator
- Natural Convection Laboratory Incubator
- Refrigerated Laboratory Incubator

Medical / IVF Equipment

Sample Handling

- Esco Multi-Zone ART Workstation
- AVT Anti-Vibration Table
- Versati™ Tabletop Centrifuge Refrigerated

Embryo Culture

- MIRI® Multiroom Incubator
- MIRI® II-12 Multiroom Incubator
- Mini MIRI® Humidity Incubator
- Mini MIRI® Dry Incubator
- CelCulture® CO₂ Incubator

Innovative Time-Lapse Imaging

- MIRI® Time-lapse Incubator

Accurate Quality Control

- MIRI® GA Gas and Temperature Validation Unit

Unique Consumables

- CultureCoin®

Healthcare

Esco Pharma Products

Airflow Containment

- BioBooth®
- Ceiling Laminar Airflow (CLAF)
- Cytoculture® Cytotoxic Safety Cabinet (CYT)
- Pharmacon™ Downflow Booth
- Esco Garment Storage Cabinet
- Esco Glassware Hoods
- Laminar Flow Horizontal/Vertical Trolley (LFH/VT)
- Laminar Flow Straddle Units
- Evidence Drying Cabinet

Isolation Containment

- Advanced Processing Platform Isolator (APPI)
- Aseptic Containment Isolator (ACTI)
- Blood Cell Labelling Isolator
- Streamline® Closed Restricted Access Barrier System (SLC-RABS)
- Containment Barrier Isolator (CBI)
 - CBI-Unidirectional (CBI-U)
 - CBI-Turbulent (CBI-T)
 - CBI-Class III Biosafety Cabinet (CBI-III)
 - CBI-Hybrid (CBI-H)
- Isoclean® Healthcare Platform Isolator (HPI)
 - HPI-G3-Without Filter Below Work Zone
 - HPI-G3-With Filter Below Work Zone
 - HPI-Inflatable Seal (HPI-IS)
 - HPI - Inflatable Seal - BioVap™ (HPI-IS-BVP)
- General Processing Platform Isolator (GPPI)
 - GPPI-Inflatable Seal (GPPI-IS)
 - GPPI-Static Seal (GPPI-SS)
- Streamline® Compounding Isolator (SCI)
- Streamline® Containment Isolator - Class III (SCI-III)
- Technetium Dispensing Isolator
- Turbulent Flow Aseptic Isolator™ (TFAI™)
- Weighing and Dispensing Containment Isolator (WDCI)

Cross Contamination Facility Integrated Barrier

- BioPass™ Pass Through
- Cleanroom Air Showers
- Dynamic Pass Boxes/ Dynamic Floor Laminar Hatches
- Infinity® Air Shower Pass Box
- Esco Sputum Booth
- Infinity® Pass Boxes
- Infinity® Cleanroom Transfer Hatch
- Soft Capsule® Soft Wall Cleanroom

Ventilation Containment

- Ventilated Balance Enclosure

Esco VacciXcell Products

Tide Motion Bioreactors

- CelXrocker™ (CXR)
- MiniTide®
- CelCradle™ (CC)
- CelCradle X® (CCX)
- TideXcell® (TXL)

Stirred Tank Bioreactors

- BioXcell®
- StirCradle™
- StirCradle™ PRO
- VXL™ Hybrid

Harvesting System

- CelShaker™
- CelCradle X® Semi-automated Harvester System (CCX-SAH)
- TideXcell® Harvester System (TXLHS)

Cell Culture Monitoring, Media and Consumables

- Super Plus™
- Plus™ Vero
- Plus™ MDCK
- Plus™ MDCK II
- BioNOC™ II macrocarriers
- GlucCell™ Glucose Monitoring System
- CVD Kit

Filling Line Equipment

- Traditional Filling Line
- cRABS (Closed Restricted Access Barrier System)
- oRABS (Open Restricted Access Barrier System)

Integrated Solutions

- Cell Processing Isolator (CPI)
- Cell Processing Center

Esco TaPestle Rx Products and Services

Pharmacy Automation and Compounding Supply

- Compounding Pharmacy Isolators (SCI, HPI, CBI, GPPI)
- Safety Cabinets and Enclosures (CYT, Class II BSC, VBE, LFC)
- Aseptic Filling Systems

Radiopharmacy Equipment

- Blood Cell Labeling Isolator
- Cytoculture® Lead-Shielded Class II Biosafety Cabinet
- Frontier® Radioisotope™ Fume Hood
- GMP-compliant Radioisotope Dispensing Isolator
- Radiopharmacy Hood (Lead Shielded Biological Safety Cabinet)
- Technetium Dispensing Isolator

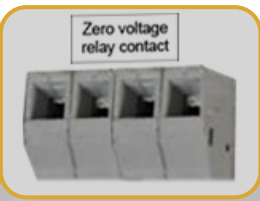

RS 232 Port and Zero Volt Relay Contact

- RS 232 Port to send operational information to Building Management System (BMS)
- Zero Volt Relay Contact to turn ON/OFF exhaust blower and signal the building alarm

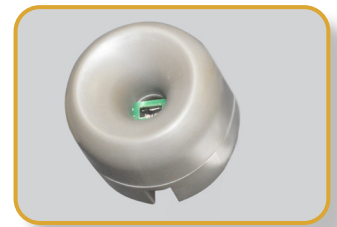

Optional Secondary H14 or Carbon Filter

H14 Filter

- 10x filtration efficiency of HEPA filter



Sentinel™ Gold Microprocessor Controller

- Displays all safety information on one screen
- Centered and angled down for easy reach & viewing



Hinged Window

- 90° opening for an easy workzone access
- 8 mm UV Resistant Polycarbonate Window
- Gasket-surrounded window to provide airtight seal for better safety.



Easy to Clean Back Wall

- Large back wall radius for easy cleaning
- With UV Lamp Provision

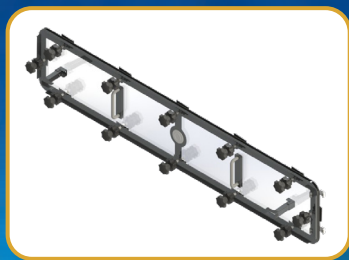

UV Door

- Safety door against UV light
- Provides air-tight seal during decontamination
- Integrated with VHP Injection Port for easy connection to VHP/HPV generator



EN12469

Esco Class I Microbiological Safety Cabinets has been certified by PHE / Public Health England (formerly HPA) for compliance to EN 12469

Airstream®

Class I Biological Safety Cabinets

Airflow Sensor

- Monitors real-time airflow for safety
- Alert the user if airflow is insufficient

Energy Efficient DC ECM Motor

- 70% Energy savings from AC motor
- Stable airflow, despite building voltage fluctuations
- Standby Mode to further reduce power consumption by 60%

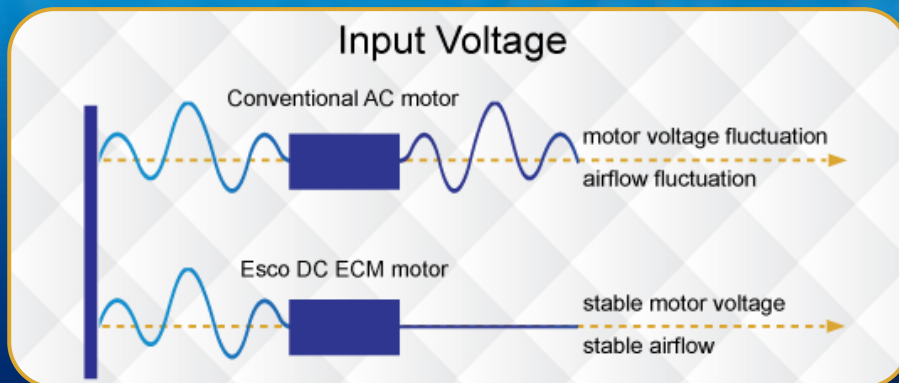
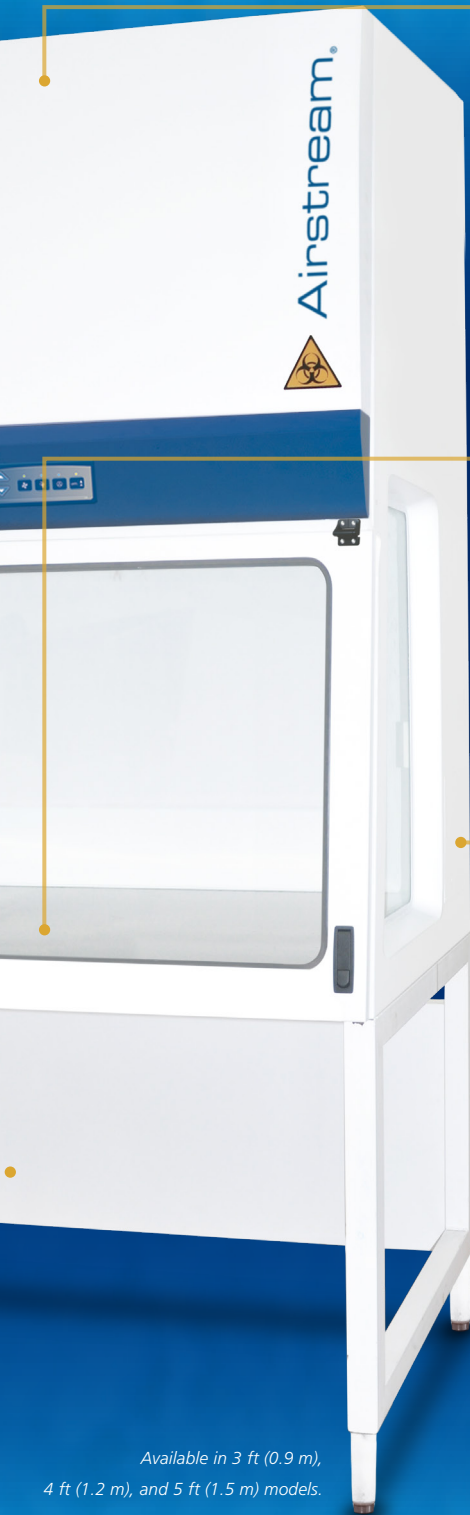

Work Top

- 1.2 mm (0.05") 18 gauge SS 304, 4B Finish
- Spill-retaining work top design with a recessed central area contains accidental liquid spills.



Isocide™ Powder Coat

- Silver-ion impregnated powder coat
- Inhibit microbial growth to improve safety

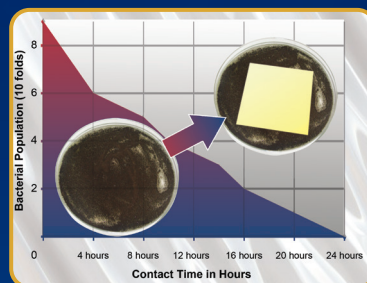

Standards Compliance

| | Biological Safety Cabinets | Filtration | Electrical Safety |
|--|---|---|---|
| | EN 12469, Europe SANS12469, South Africa | EN-1822 (H14), Europe IEST-RP-CC001.3, USA IEST-RP-CC007, USA IEST-RP-CC034.1, USA | IEC61010-1, Worldwide EN-61010-1, Europe |

Available in 3 ft (0.9 m), 4 ft (1.2 m), and 5 ft (1.5 m) models.

TECHNICAL SPECIFICATIONS

| Model | | AC1-3E8 (2010650) | AC1-4E8 (2010732) | AC1-5E8 (2010879) |
|--|---|---|---|---|
| External Dimensions (W x D x H) | | 1035 mm x 731 mm x 1395 mm (40.7" x 28.8" x 55") | 1340 x 731 x 1395 mm (52.8" x 28.8" x 55") | 1645 x 731 x 1395 mm (64.8" x 28.8" x 55") |
| Gross Internal Dimensions (W x D x H) | | 860 x 668 x 670mm (33.9" x 26.3" x 26.4") | 1165 x 668 x 670 mm (45.9" x 26.3" x 26.4") | 1470 x 668 x 670 mm (57.9" x 26.3" x 26.4") |
| Usable Work Area | | 0.57 m ² (6.1 sq.ft) | 0.76 m ² (8.2 sq.ft) | 0.95 m ² (10.2 sq.ft) |
| Maximum Window Opening (at 90° opening) | | 556 mm (21.9") | | |
| Working Opening/ Tested Opening | | 200 mm (7.9") | | |
| Average Inflow Velocity | | 0.85 m/s (167 fpm) | | |
| Airflow Volume | Inflow | 562 m ³ /h (331 cfm) | 747 m ³ /h (440 cfm) | 933 m ³ /h (549 cfm) |
| | Exhaust | 562 m ³ /h (331 cfm) | 747 m ³ /h (440 cfm) | 933 m ³ /h (549 cfm) |
| | Required Exhaust with Optional Thimble Exhaust Collar | 730 m ³ /h (430 cfm) | 971 m ³ /h (4572 cfm) | 1213 m ³ /h (714 cfm) |
| | Static Pressure for Optional Thimble Exhaust Collar | 70 Pa (0.28 in H ₂ O) | 85 Pa (0.34 in H ₂ O) | 100 Pa (0.40 in H ₂ O) |
| HEPA Filter Typical Efficiency | | >99.999% at 0.1 to 0.3 micron, ULPA as per IEST-RP-CC001.3 USA >99.999% at MPPS, H14 as per EN 1822 EU | | |
| Sound Emission in Typical Lab Room per EN 12469 | | 47.8 dBA | 48.4 dBA | 52 dBA |
| LED Lamp Intensity | | >1000 lux (>92 ft.cd) | | |
| Cabinet Construction | Main body | 1.2 mm (0.05")/18 gauge EG Steel with Isocide™ Oven-Baked Epoxy-Polyester Powder Coating | | |
| | Work Zone | Tray: 1.2 mm (0.05")/18 gauge, SS 304, 4B Finish | | |
| | Side Walls | 5 mm (0.2") UV Absorbing Tempered Glass | | |
| Electrical | Cabinet Full Load Amps (FLA) | 8.2 A | | |
| | Heat Load (BTU / Hr) | 341 | 450 | 556 |
| Nominal Power Consumption | | 100 W | 132 W | 163 W |
| Net Weight * | | 241 kg (531 lbs) | 301 Kg (664 lbs) | 363 Kg (800 lbs) |
| Shipping Weight * | | 296 kg (625 lbs) | 356 Kg (785 lbs) | 418 Kg (922 lbs) |
| Shipping Dimensions, Maximum (W x D x H)* | | 1200 mm x 850 mm x 1950 mm (47.2" x 33.5" x 76.8") | 1450 mm x 850 mm x 1950 mm (57.1" x 33.5" x 76.8") | 1720 x 850 x 1950 mm (67.7" x 33.5" x 76.8") |
| Shipping Volume, Maximum * | | 2.0 m ³ (70.64 cu.ft) | 2.5 m ³ (88.2 cu. ft) | 3.0 m ³ (105.9 cu.ft) |

* Cabinet only, excludes optional stand.

Accessories for AC1 Biological Safety Cabinets

| | | AC1-3E8 | AC1-4E8 | AC1-5E8 |
|---------------------------------------|---|--------------------------------|--------------------------------|--------------------------------|
| Optional Secondary Filter | Secondary H14 Filter | HP-AC1-3 5080228 | HP-AC1-4 5080138 | HP-AC1-5 5080229 |
| | Secondary Carbon Filter | CRF/SEC-AC1-3 5080226 | CRF/SEC-AC1-4 5080139 | CRF/SEC-AC1-5 5080227 |
| Exhaust Ducting | Exhaust Hard Ducting (with VHP out Port) | EHD AC1-3 5172154 | EHD AC1-4 5170666 | EHD AC1-5 5170796 |
| | Anti-blowback Valve 10" | ABBV-10P 5170352 | | |
| | Tri-safe Exhaust Collar with Alarm | TEM-4 2010606 | | |
| | Exhaust Damper | B2-DAMPER 5170352 | | |
| Hydrogen Peroxide Decontamination Kit | UV Door (with VHP In Port) | UV DOOR AC1-3 5072158 | UV DOOR AC1-4 5090044 | UV DOOR AC1-5 5072159 |
| | VHP Out Top Box for Cabinet WITHOUT Exhaust Collar Installed (Ø 1") | VHP OUT TOP BOX 3ft 5172156 | VHP OUT TOP BOX 4ft 5170665 | VHP OUT TOP BOX 5ft 5072157 |
| Work Zone | UV Lamp | UV-15A-L 5170251 | UV-30A-L 5170255 | UV-30A-L 5170255 |
| | IV Bar | IV-910 5170499 | IV-1215 5170231 | IV-1520 5170500 |
| | Pre-filter | 5090093 | 5090045 | 5090076 |
| Electrical Outlet | Universal | EO-UNI 5170060 | | |
| Service Fixtures | EU SF-Gas-20 mm | SF-1G20 5170410 | | |
| | EU SF-Vacuum-20 mm | SF-1V20 5170457 | | |
| | EU SF-Air-20 mm | SF-1A20 5170502 | | |
| | EU SF-Nitrogen-20 mm | SF-1N20 5170503 | | |
| | EU SF-Water-20 mm | SF-1W20 5170458 | | |
| | EU SF-Universal-22 mm | SF-2U22 5170504 | | |
| Support Stands, Ships Flat | Fixed Stand with Leveling Feet, 28" height | SAL-3A0 Gen 2 5130170 | SAL-4A0 Gen 2 5130134 | SAL-5A0 Gen 2 5130171 |
| | Fixed Stand with Leveling Feet, 34" height | SAL-3B0 Gen 2 5130174 | SAL-4B0 Gen 2 5130175 | SAL-5B0 Gen 2 5130176 |
| | Fixed Stand with Caster Wheels, 28" height | SPC-3A0 Gen 2 5130013 | SPC-4A0 Gen 2 5130152 | SPC-5A0 Gen 2 5130162 |
| | Fixed Stand with Caster Wheels, 34" height | SPC-3B0 Gen 2 5130018 | SPC-4B0 Gen 2 5130166 | SPC-5B0 Gen 2 5130167 |
| | Motorized Height Stand with Caster Wheels | SPM-3A_ | SPM-4A_ | SPM-5A_ |
| Misc | IQ OQ Protocol | 9010179 | | |

AC1 Biological Safety Cabinet Engineering Drawing

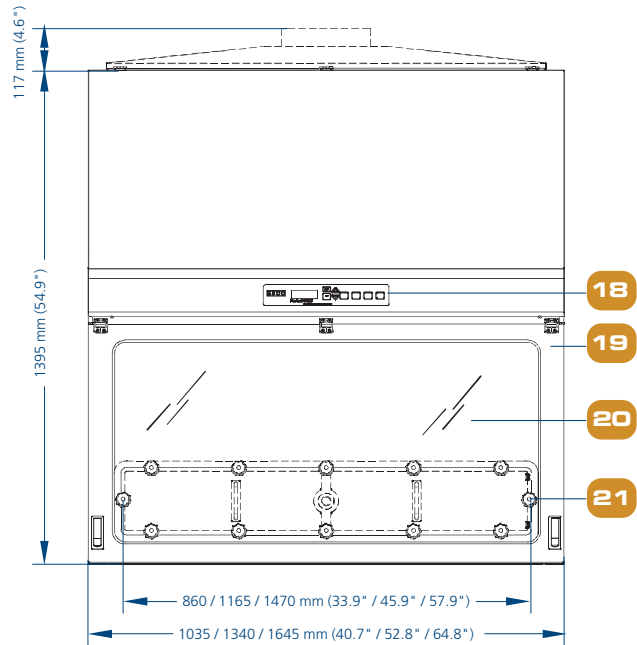
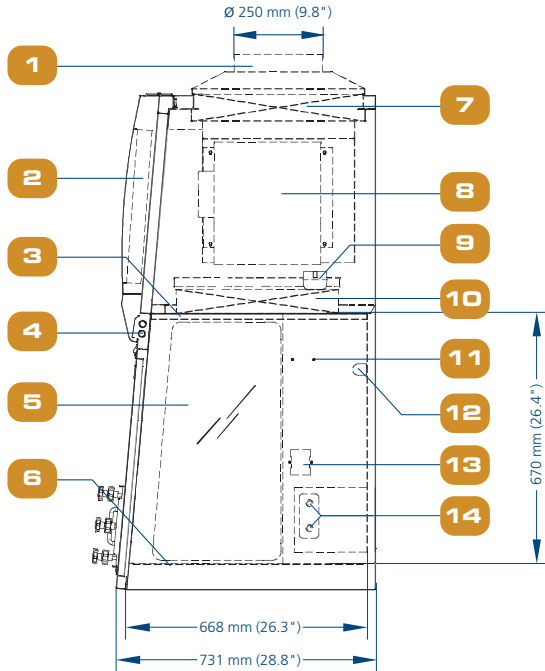
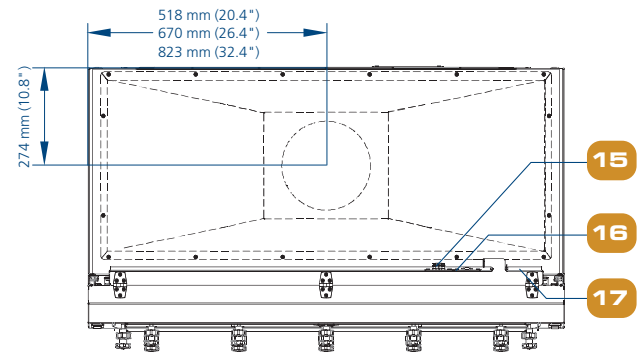

- | | | | |
|-----------------------------------|---|--|--|
| 1. Exhaust Ducting (optional) | 7. Optional Secondary H14 Filter / Carbon filter) | 13. Standard Electrical Outlet Kit Provision | 18. Sentinel™ Gold Microprocessor System |
| 2. Electrical Panel | 8. DC ECM Blower | 14. Service Fixtures Kit Provision (2 on each side) | 19. Hinged Front Door |
| 3. Diffuser / Optional Pre-filter | 9. Inflow Sensor | | 20. 8 mm UV Resistant Polycarbonate Window |
| 4. LED Lamp | 10. Main H14 Filter | | 21. Air Tight UV / Decontamination Panel |
| 5. Side Tempered Glass | 11. IV Bar Retrofit Kit Provision | | |
| 6. Stainless Steel Table | 12. UV Lamp Provision | 15. 2 Sets Zero Volt Relay Contact | |
| | | 16. RS 232 Port | |
| | | 17. Power Inlet | |

Follow us on social media, download our apps,
and scan the QR code for more info.



@Escolifesciences



@Escolifesciences



@Escolifesci



@Esco



@Escolifesciences



@Escolifesciences



Esco Lifesciences



Esco Lifesciences

ESCO

LIFESCIENCES GROUP

Esco Micro Pte. Ltd. • 19 Changi South Street 1 • Singapore 486779
Tel +65 6542 0833 • mail@escolifesciences.com
www.escolifesciences.com

Esco Technologies, Inc. • 903 Sheehy Drive, Suite F, Horsham, PA 19044, USA
Tel: +1 215-441-9661 • Fax 484-698-7757
eti.admin@escolifesciences.com

Esco Lifesciences Group Offices: Bangladesh | China | Denmark | Germany | Hong Kong | India | Indonesia | Italy | Japan | Lithuania | Malaysia | Myanmar | Philippines | Russia | Singapore | South Africa | South Korea | Taiwan | Thailand | UAE | UK | USA | Vietnam

9010184_Biological Safety Cabinet_AC1_ve_050426

Esco can accept no responsibility for possible errors in catalogues, brochures and other printed materials. Esco reserves the right to alter its products and specifications without notice. All trademarks and logotypes in this material are the property of Esco and the respective companies.